



DATA SHEET

Product: Evo Core

Product Code: 03-10001

Doc Iss: 04





DATA SHEET

Product: Evo Core

Product Code: 03-10001

Dimensions: Millimetre (mm)

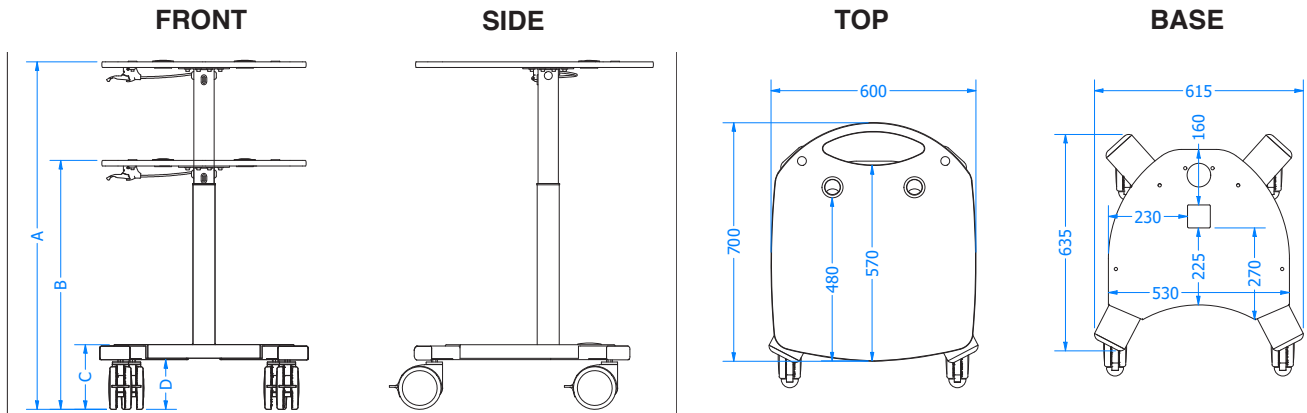

DIMENSION:	A	B	C	D
Single Castor:	1035	750	205	165
Dual Castor:	1020	735	190	150

Key Features:

- Height Adjustable (range is 290mm as standard)
- Lever positioned on the left or right
- Large High Pressure Laminate (HPL) top with rear handle 20kg max load (*other load options available*)
- Heavy duty steel base, ergonomic curved front recess
- Cable entry holes on both top and base
- Accessory mounting holes on both top and base
- 4 off braking swivel castors (Dual wheel only)
- High ground clearance
- Material(s): HPL, Aluminium, Steel, Plastic
- Finish(s): Anodised, Powder Coat Black Grey RAL7021 (*other colours are available*)
- Weight: 28kg

Cleaning

- Refer to the Evo Carts cleaning guide for detailed information
- Tested active agents
 - ✓ Detergent & Disinfectants
 - ✓ Alcohol Based
 - ✓ Ammonia
 - ✓ Chlorine

Operation and Maintenance

- Secure any loose items before moving.
- Carefully lift castors over large thresholds.
- Periodic general inspection, check fixings are secure, check free movement of any moving part.

While every effort is made to ensure the accuracy of our information, Evo Carts accept no liability for the accuracy of the information contained in this document and reserve the right to modify the specifications or data contained herein without prior notification.